

quick guide bsp

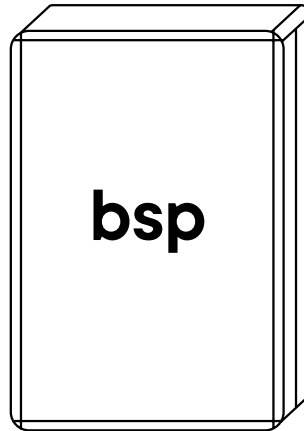



designed and assembled
by studer in Switzerland



Introduction

EN Congratulations!

You are about to install and use a high-end equipment that will play a central role in the energy management of your battery-based system. The bsp is a battery status processor for advanced monitoring of lead-acid batteries within an xtender system. This device has been designed, manufactured, assembled and tested in our factory in Switzerland. It has a 5-year warranty.

FR Félicitations!

Vous vous préparez à installer et à utiliser un appareil haute-gamme qui jouera un rôle central dans la gestion d'énergie de votre système avec stockage. Le bsp, battery status processor, est un accessoire de monitoring avancé des batteries au plomb dans un système xtender. Cet appareil a été conçu, fabriqué, assemblé et testé dans notre usine en Suisse. Il bénéficie d'une garantie de 5 ans.

DE Herzlichen Glückwunsch!

Wir freuen uns, dass Sie sich für eines High-Tech-Gerät entschieden haben, welches bei der Energie-management Ihrer Anlage entscheidende Rolle spielen wird. Der bsp ist Batteriestatusprozessor zur erweiterten Überwachung von Blei-Säure-Batterien in einem Xtender-System. Dieser Gerät wurde in unserem Werk in der Schweiz entwickelt, hergestellt, montiert und getestet. Es hat eine 5-jährige Garantie.

ES ¡Enhorabuena!

Está a punto de instalar y de utilizar un equipo de alta gama que desempeñará una función esencial en la gestión de energía de su sistema con almacenamiento. El bsp, battery status processor, es un accesorio para la monitorización avanzada de baterías de plomo en un sistema xtender. Este equipo ha sido diseñado, fabricado, ensamblado y probado en nuestra fábrica en Suiza. Tiene una garantía de 5 años.

General Information

EN Exclusion of liability

Studer disclaims all responsibility and liability for damage, costs or losses resulting from an installation that does not comply with the instructions, a faulty operation or inadequate maintenance. The use of studer equipment is in any case under the responsibility of the customer.

Read carefully the safety and operation instructions / Installation must be entrusted to qualified personnel / Check the user manual online / Need help ?

FR Exclusion de la responsabilité

Studer décline toute responsabilité pour les dommages, les coûts ou les pertes résultant d'une installation non conforme aux prescriptions, d'un fonctionnement défectueux, ou d'un entretien déficient. L'utilisation des appareils studer relève dans tous les cas de la responsabilité du client.

Lisez attentivement les instructions de sécurité et d'utilisation / L'installation doit être confiée à du personnel qualifié / Consultez le manuel d'utilisation en ligne / Besoin d'aide ?

DE Haftungsausschluss

Studer übernimmt keinerlei Verantwortung und Haftung für Schäden, Kosten oder Verluste, die sich aus unsachgemäßer Installation, unsachgemäßem Betrieb sowie fehlerhafter Wartung ergeben oder in irgendeiner Art und Weise damit zusammenhängen. Der Einsatz und Betrieb der studer-Geräte obliegt in jedem Fall der Verantwortung des Kunden.

Lesen Sie die Sicherheits- und Betriebsanweisungen sorgfältig durch / Die Installation muss qualifiziertem Personal anvertraut werden / Überprüfen Sie die Bedienungsanleitung online / Brauchen Sie Hilfe ?

ES Excepción de responsabilidad

Studer declina cualquier responsabilidad por los daños, costes o pérdidas resultantes de una instalación no conforme con las recomendaciones, de un funcionamiento defectuoso o de un mantenimiento deficiente. El uso de equipos de studer es en cualquier caso responsabilidad del cliente.

Lea atentamente las instrucciones de seguridad y funcionamiento / La instalación debe confiarse a personal cualificado / Consulte el manual de usuario en línea / ¿Necesitas ayuda?

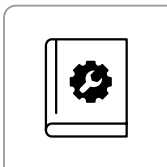

Compatible with:



rcc 02/03
Configuration, display, datalogger

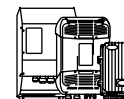

xtender
Battery inverter/charger

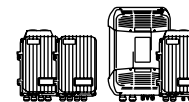

vario
Solar charge controller



xcom LAN/GSM
Remote monitoring (Portal & App)



xcom 232i/CAN/485i
Communication bridges (openstuder)



bts 01
Temperature sensor

Mounting and installation

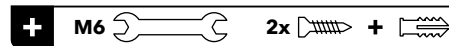

Storage and content

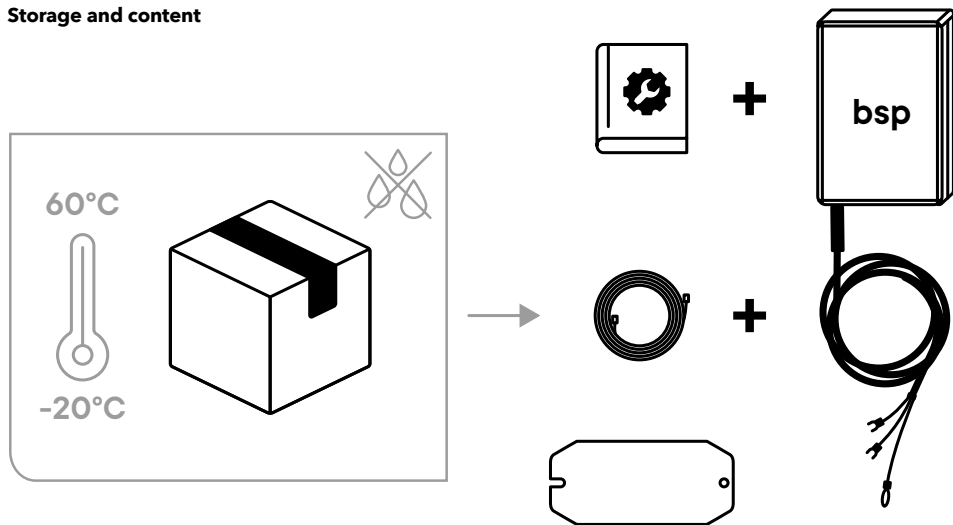

Mounting place

The bsp should only be installed by qualified personnel.

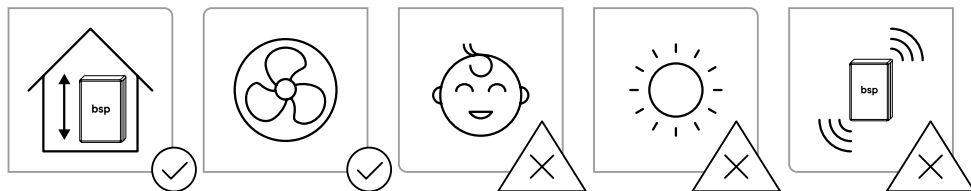

Fixing and dimensions

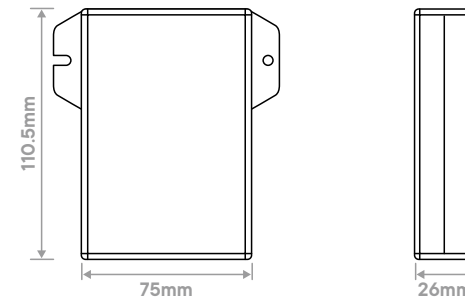
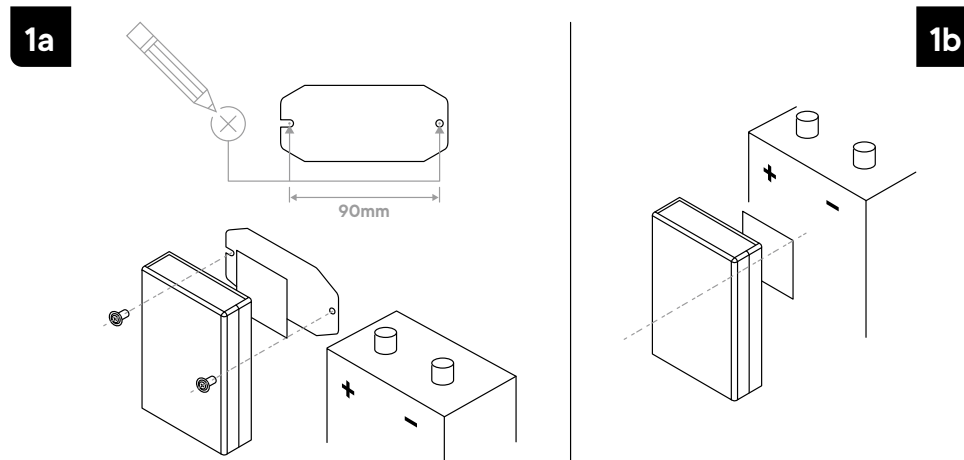

Wiring

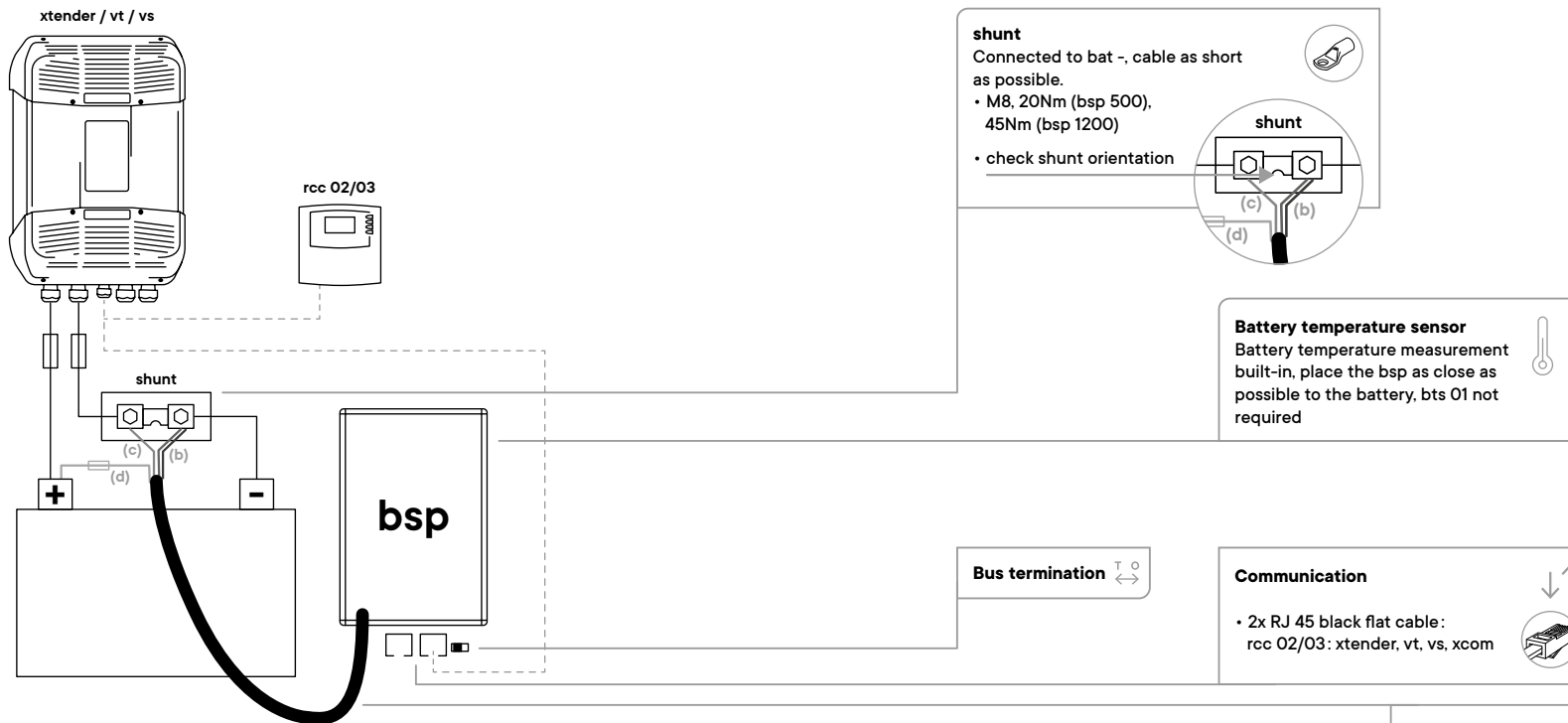

- EN** The device must be installed in accordance with local standards and regulations in force.
- FR** L'appareil doit être installé conformément aux normes et réglementations locales en vigueur.
- DE** Das Gerät muss gemäß den geltenden örtlichen Normen und Vorschriften installiert werden.
- ES** El dispositivo debe instalarse de acuerdo con las normas y regulaciones locales vigentes.

Measurement cables

Cables included:

- black&yellow (b) to shunt, confirm orientation
- blue (c) to shunt, confirm orientation
- red (d) to bat +, fuse included (500mA)

Multi units and power up

1 bsp per system

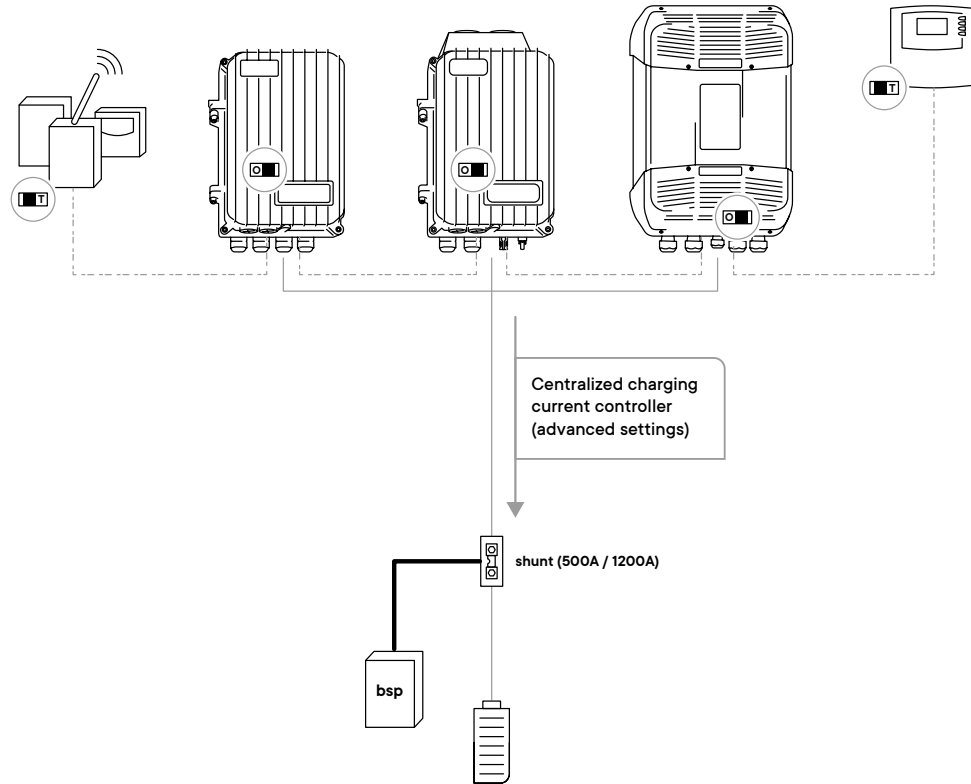

Display

Display system

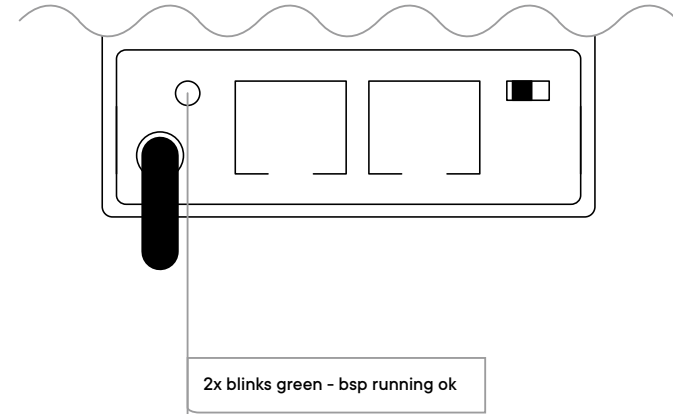

Configuring the xtender

rcc 02/03

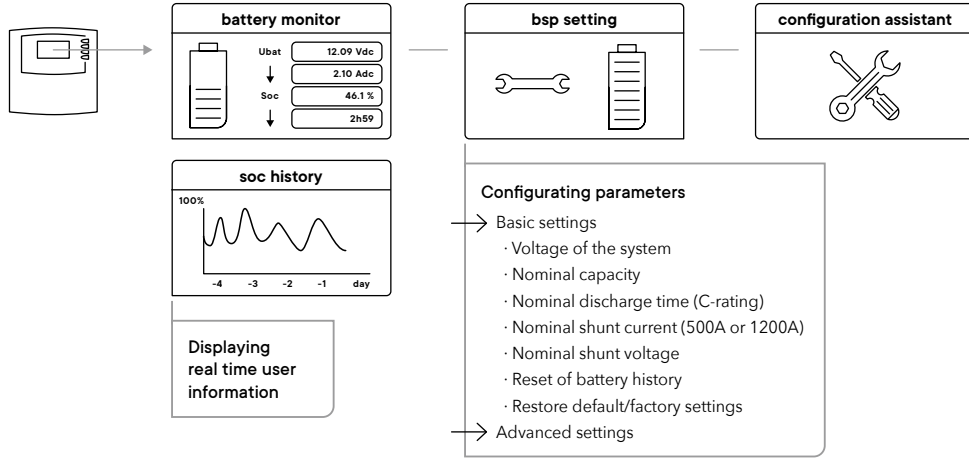

Technical data

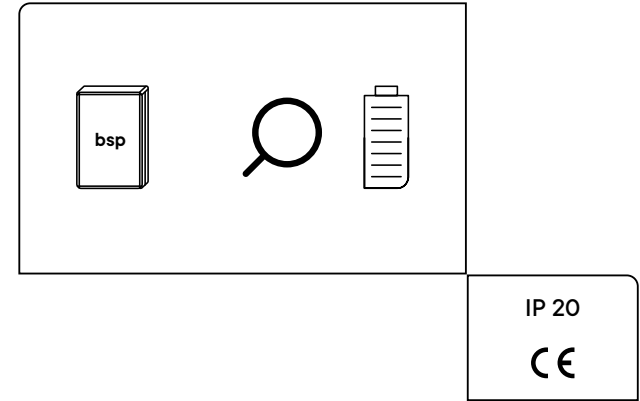

Supply voltage range	7 ... 85Vdc
Supply current	9 mA @ 12V
	5 mA @ 24V
	3 mA @ 48V
Input voltage range	7 ... 85Vdc
Shunt measurement input range	± 195 mV
RMS continuous current @ 25°C	± 500 A (bsp 500)
	± 1200 A (bsp 1200)
Maximum measurable peak current	± 1950 A (bsp 500)
	± 4680 A (bsp 1200)
Voltage measurement accuracy	0.3%
Current measurement accuracy	0.5%
Battery capacity	20 ... 20000 Ah
Operating temperature range	-20 ... 55°C



Maintenance and recycling

EN Maintenance and recycling

Except for the periodic check of the connections (tightening, general condition), the bsp does not require any particular maintenance. To dispose of this product, please use the service for the collection of electrical waste and observe all obligations in force in the place of purchase.

FR Entretien et recyclage

À l'exception du contrôle périodique des branchements (serrage, état général), le bsp ne nécessite pas d'entretien particulier. Pour vous débarrasser de ce produit, veuillez utiliser les services de collecte des déchets électriques et observer toutes les obligations en vigueur selon le lieu d'achat.

DE Wartung und Recycling

Abgesehen von der regelmäßigen Kontrolle der Anschlüsse (Fixierung, allgemeiner Zustand) bedarf der bsp keinerlei besonderer Wartungsarbeiten. Beachten Sie bei der Entsorgung dieses Gerätes die geltenden örtlichen Vorschriften und nutzen Sie die Sammeldienste/-stellen für Elektro-/Elektronik-Altgeräte.

ES Mantenimiento y reciclaje

A excepción del control periódico de las conexiones (apriete, estado general), el bsp no requiere un mantenimiento particular. Para la eliminación del producto, acuda a los servicios de recogida de residuos eléctricos y cumpla todas las obligaciones vigentes en el lugar de compra.

Serial Number:

Installed by:

Date:

Signature:

Call our specialists **+41 27 205 60 80**
or visit **studer-innotec.com/support**

Studer Innotec SA
rue des Casernes 57
1950 Sion, Switzerland

info@studer-innotec.com

4092

